

NOTICE DE MONTAGE  
**ASSEMBLING INSTRUCTION**  
 INSTRUZIONI DI MONTAGGIO  
**MONTAGEANLEITUNG**  
 INSTRUÇÕES DE MONTAGEM  
**MANUAL DE MONTAJE**  
 INSTRUKCJE MONTAŻU

# SE - 23

AVANT DE COMMENCER, SE  
 REPORTER AUX CONSEILS  
 DE MONTAGE EN ANNEXE

ANTES DE COMERCAR, ADRIASE AOS  
 CONSELHOS DE  
 MONTAGEM EM ANEXO

BEFORE STARTING, REFER  
 TO THE ASSEMBLING ADVICE  
 IN ANNEX

ANTES DE EMPEZAR  
 CONSULTE LOS CONSEJOS  
 PARA EL MONTAJE

AVANTI DI COMMINCIARE,  
 RIPORTAGE AGLI CONSIGLI DI  
 MONTAGIO





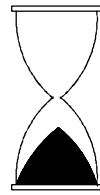
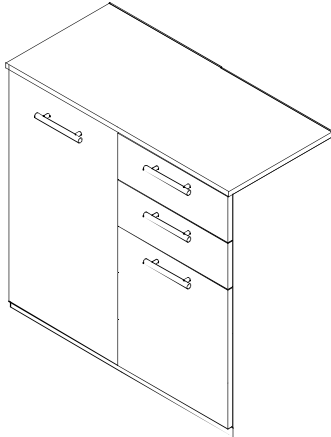



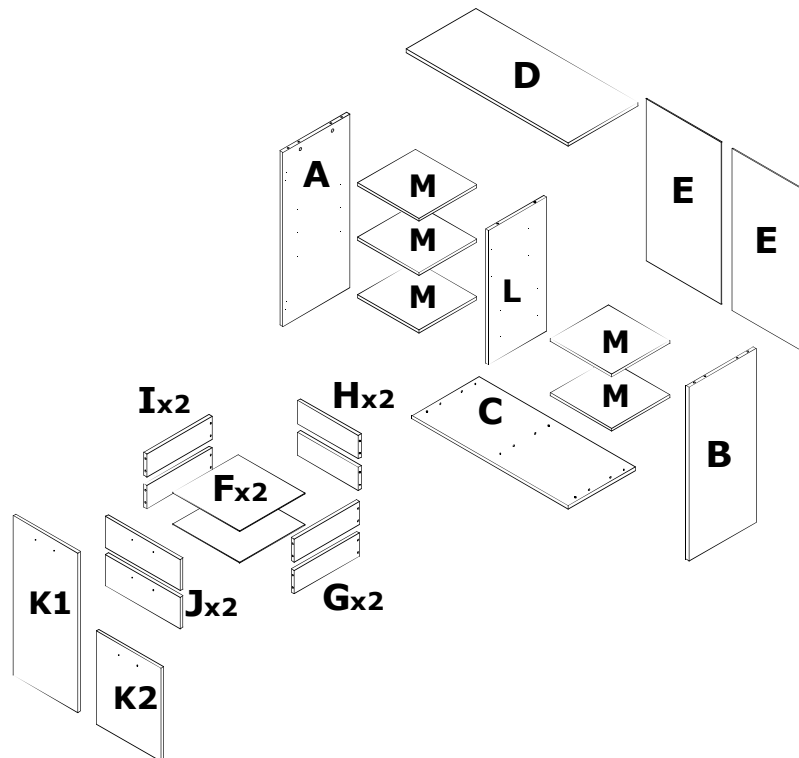
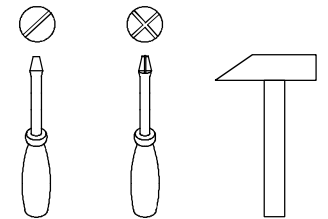
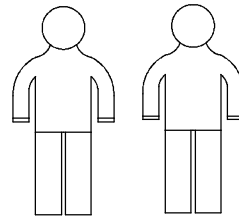



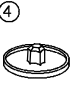

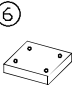

PRZED ROZPOCZECIEM  
 ZAPOZNAĆ SIĘ Z ZAŁĄCZONĄ  
 INSTRUKCJĄ MONTAŻU

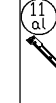
VOR DIE MONTAGE, BITTE  
 BEILIEGENDE ANWEISUNGEN  
 FOLGEN





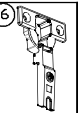

60 min



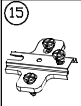

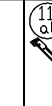

																
6	20	6	6	14	6	4	16	40	24	3	3	3	3	8	20	1
																
4	4															

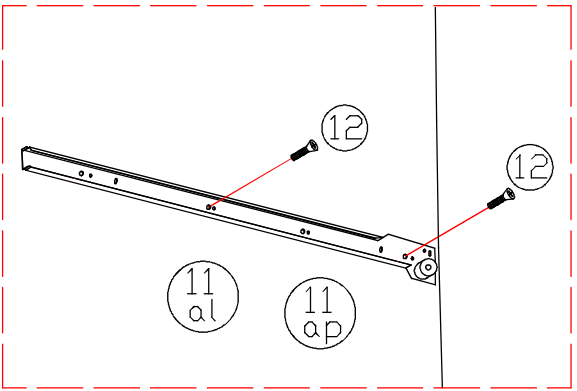
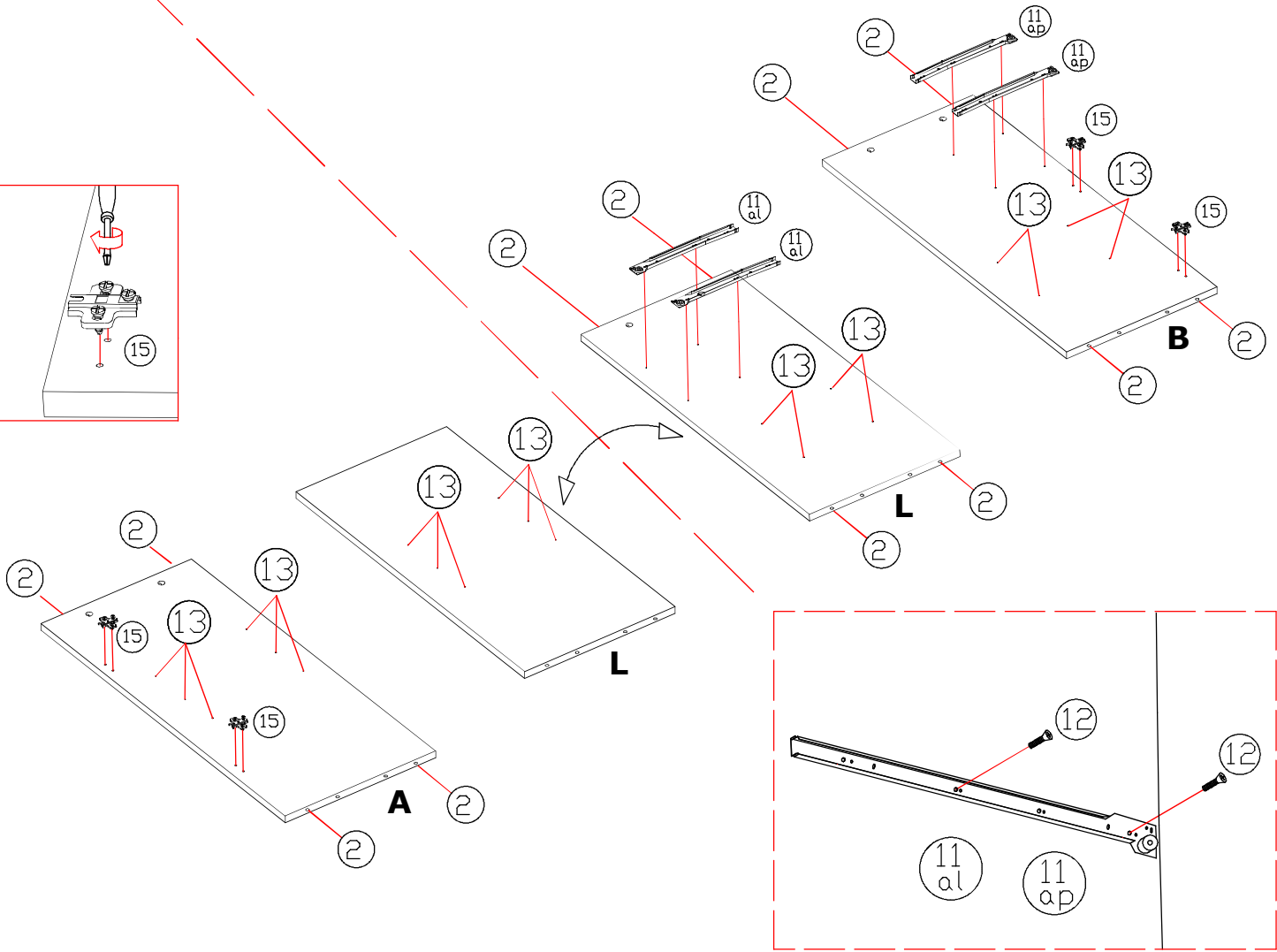
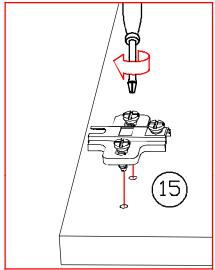
# 1

					
4	20	8	2	2	12



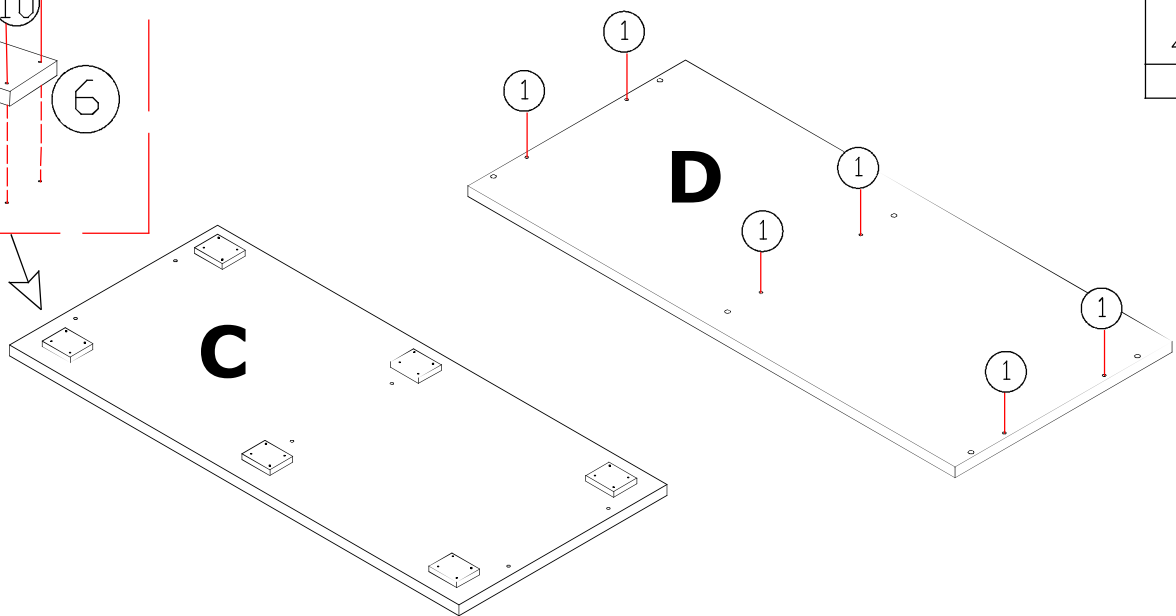
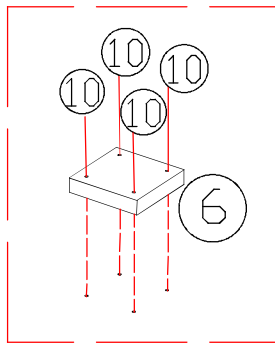

# 2

	
6	6
	
4x25	6
24	6



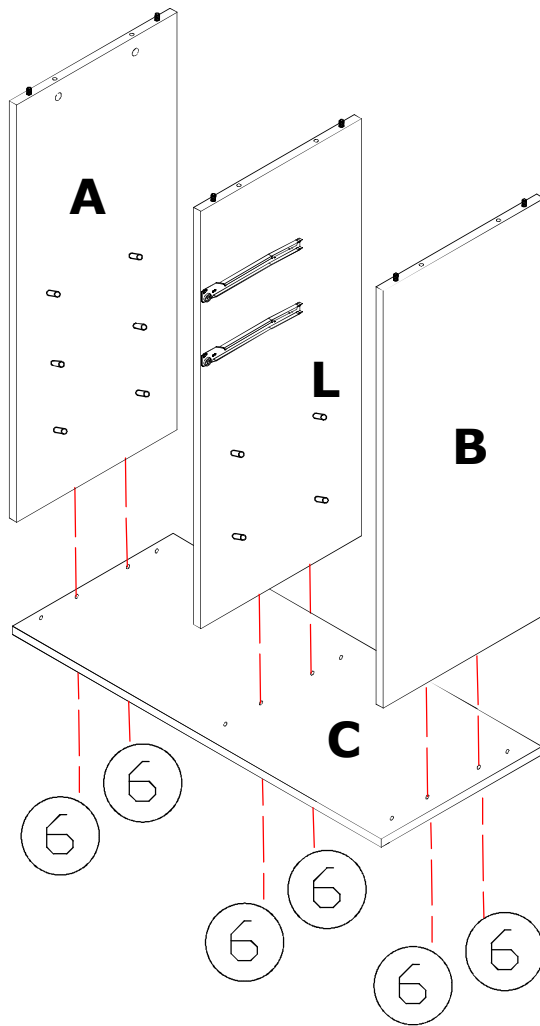

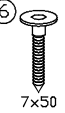
3

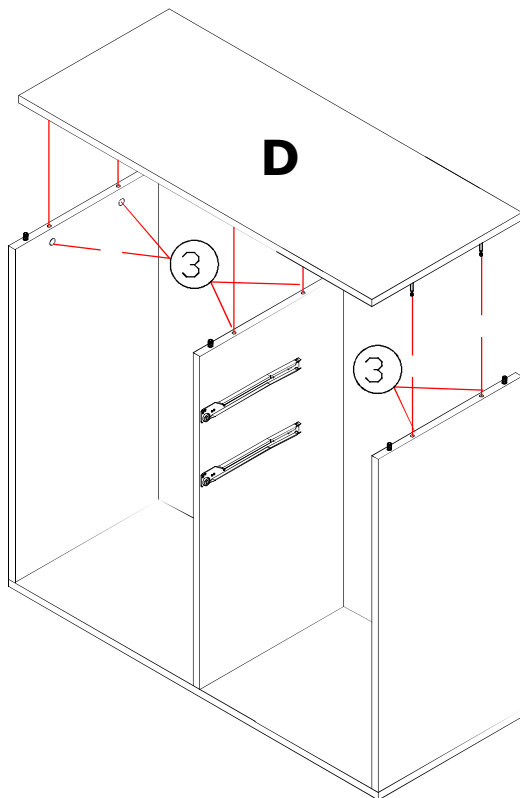

6	5
	
7x50	
6	6

4



3	4
	
6	6

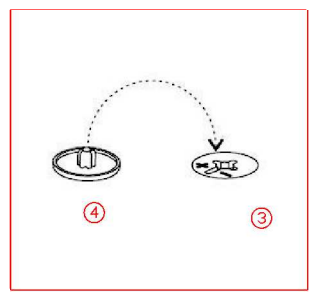
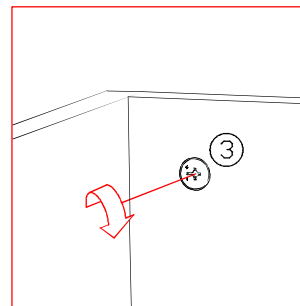
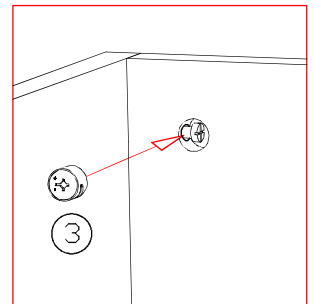
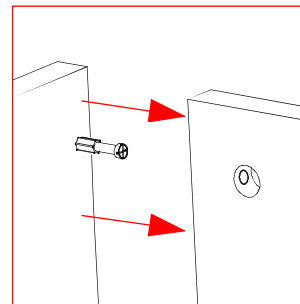

5

9  
2x30  
35

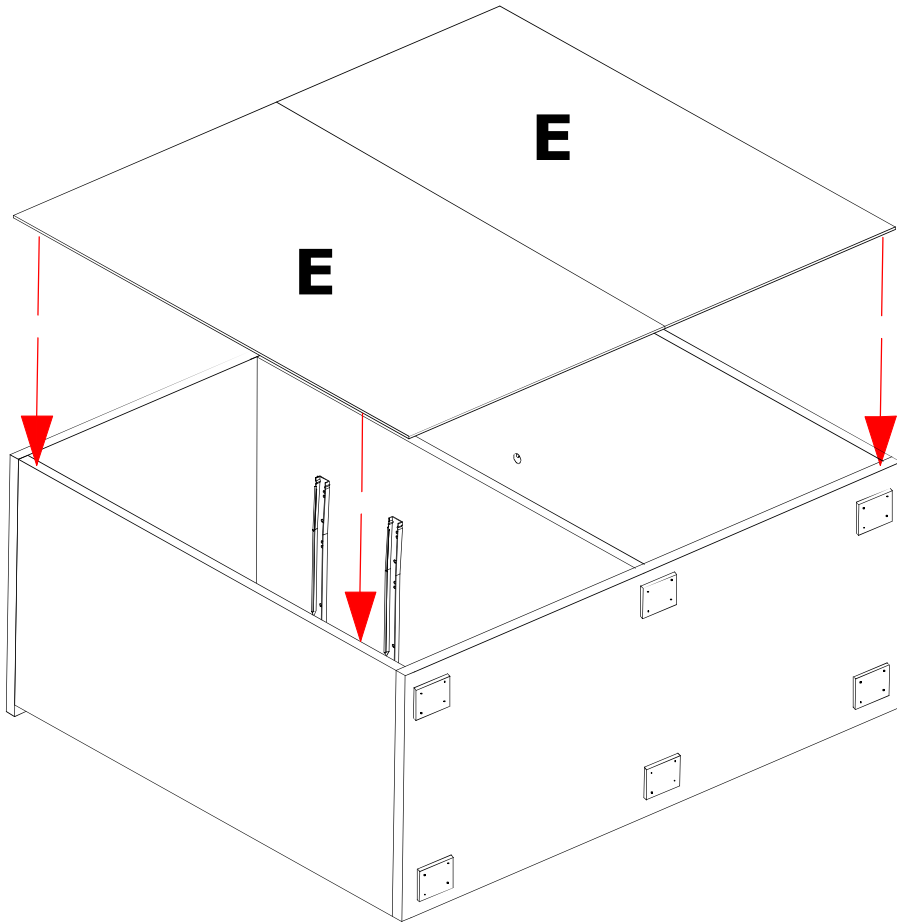

A=B

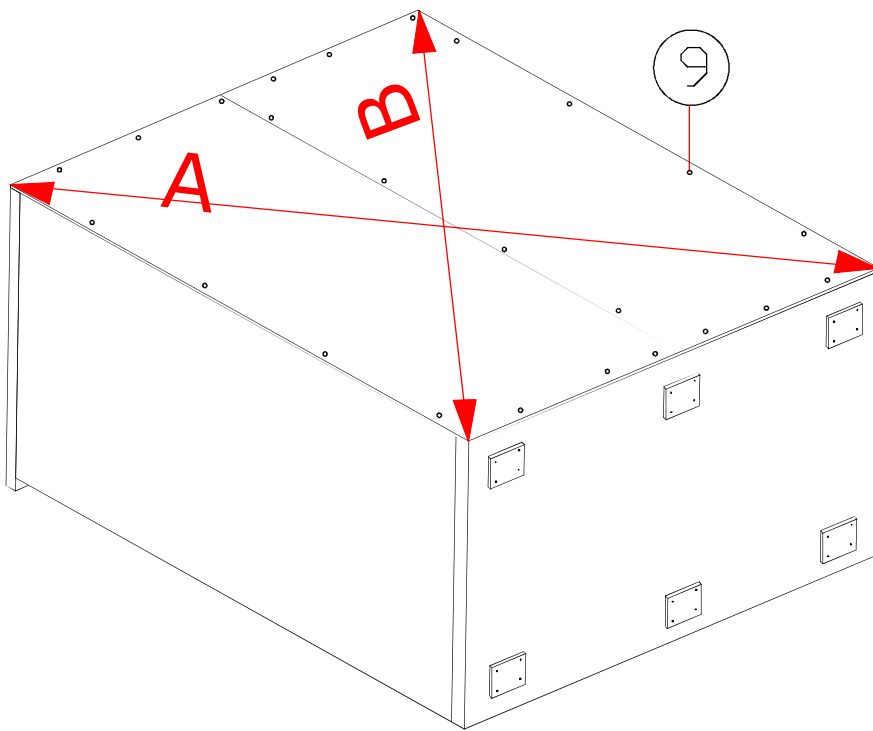

**6**  
**2x**

⑤	②	⑭
7x50		GLUE
8	8	1

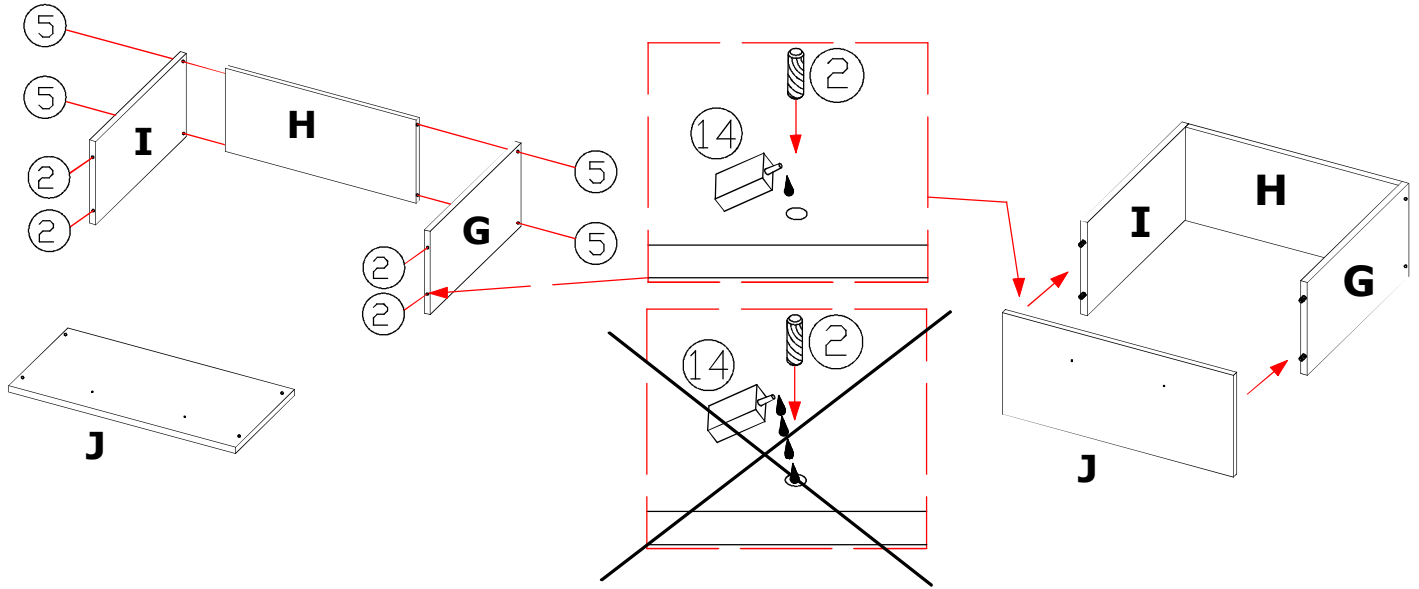

**7**  
**2x**

⑨
2x30
10

⑧	⑪ bl	⑪ bp
3,5x16		
8	2	2

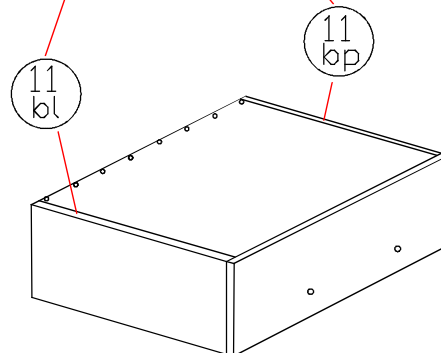
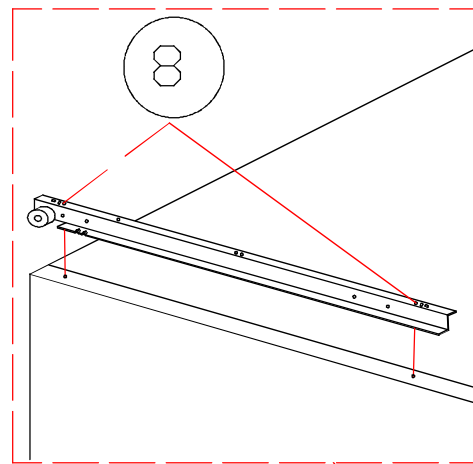
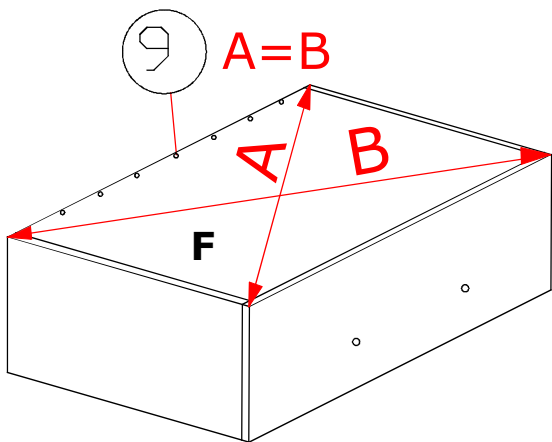

**8**

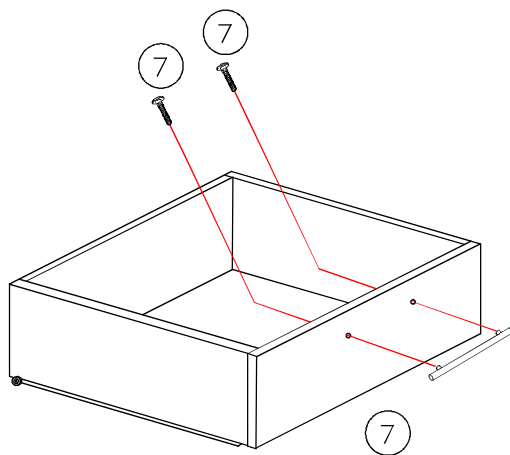
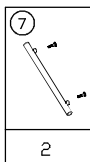

**9**

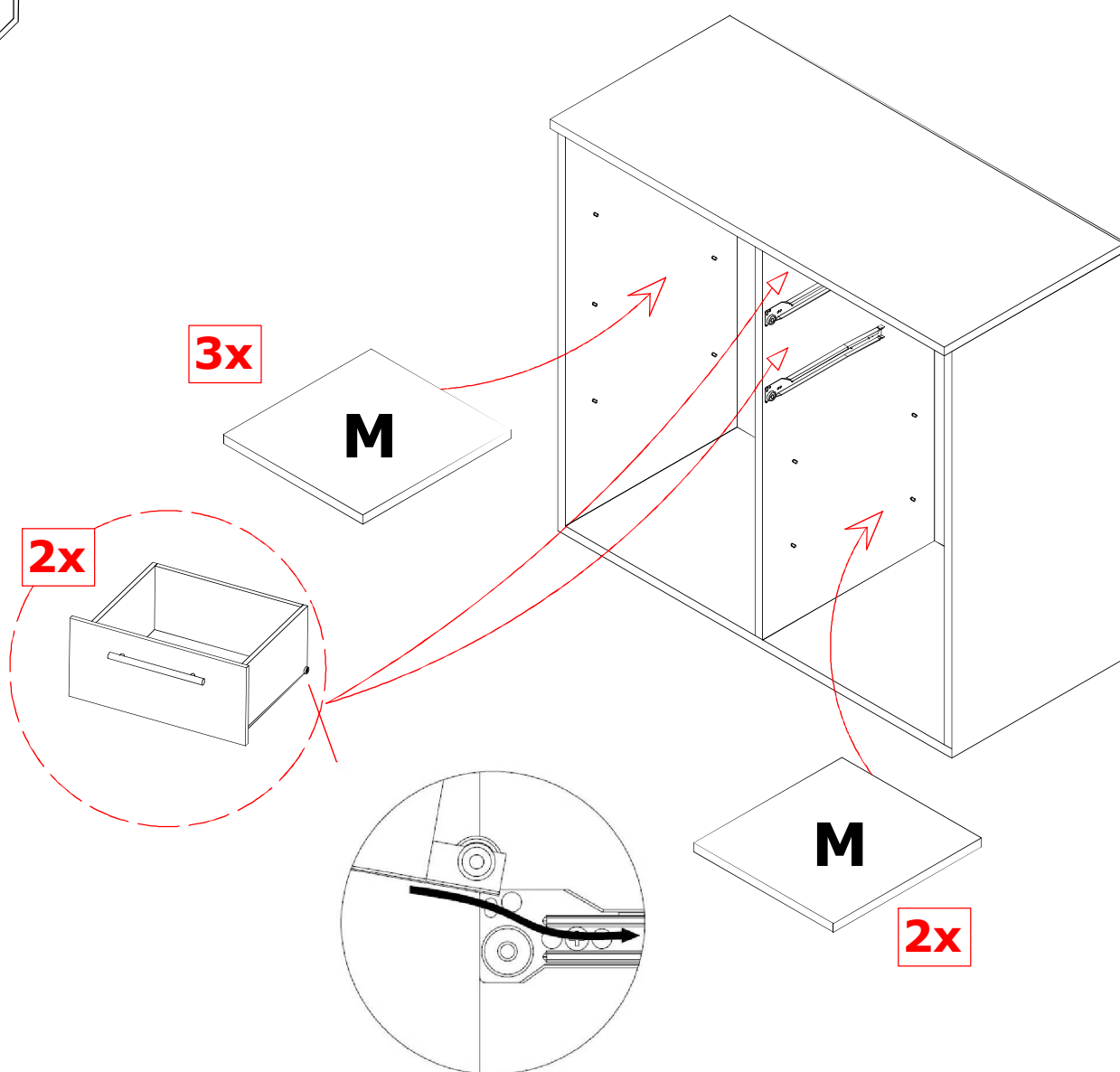

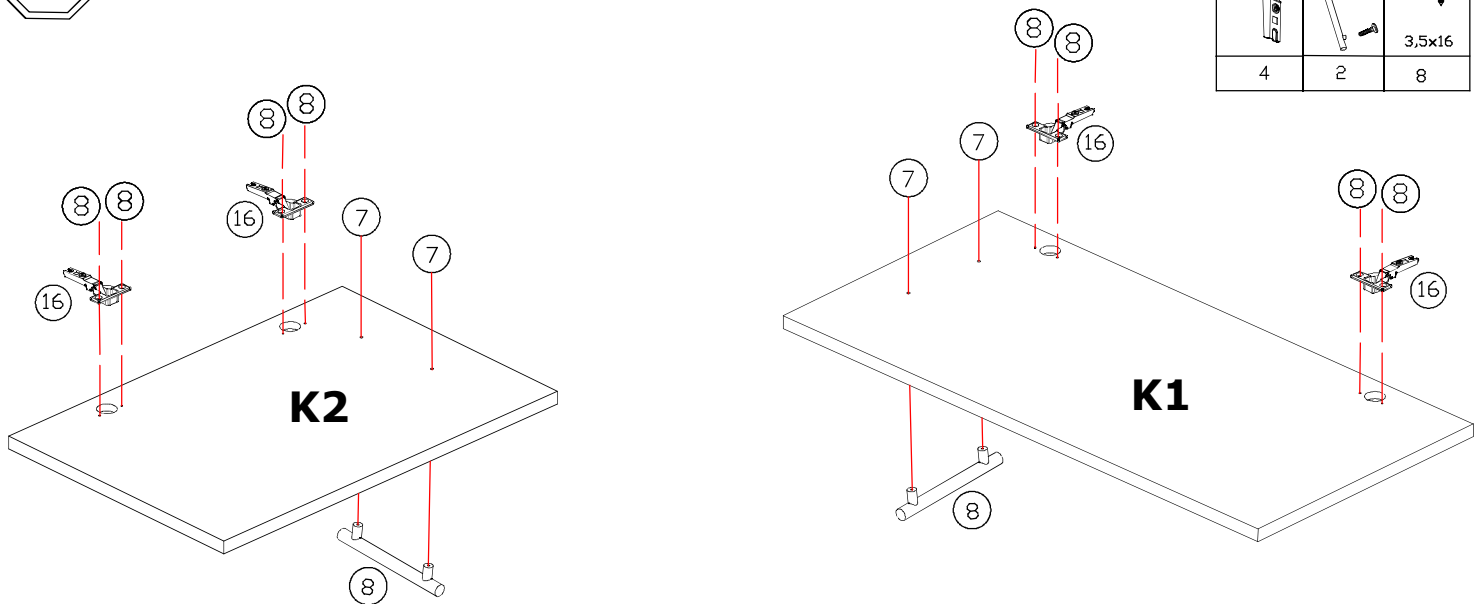
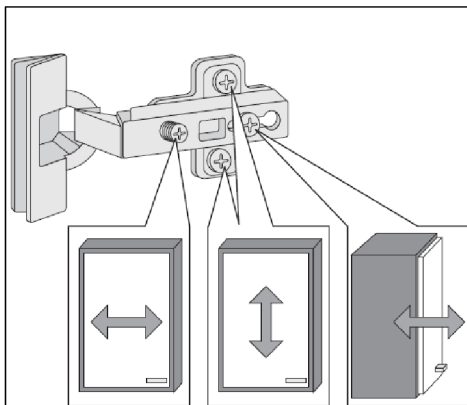
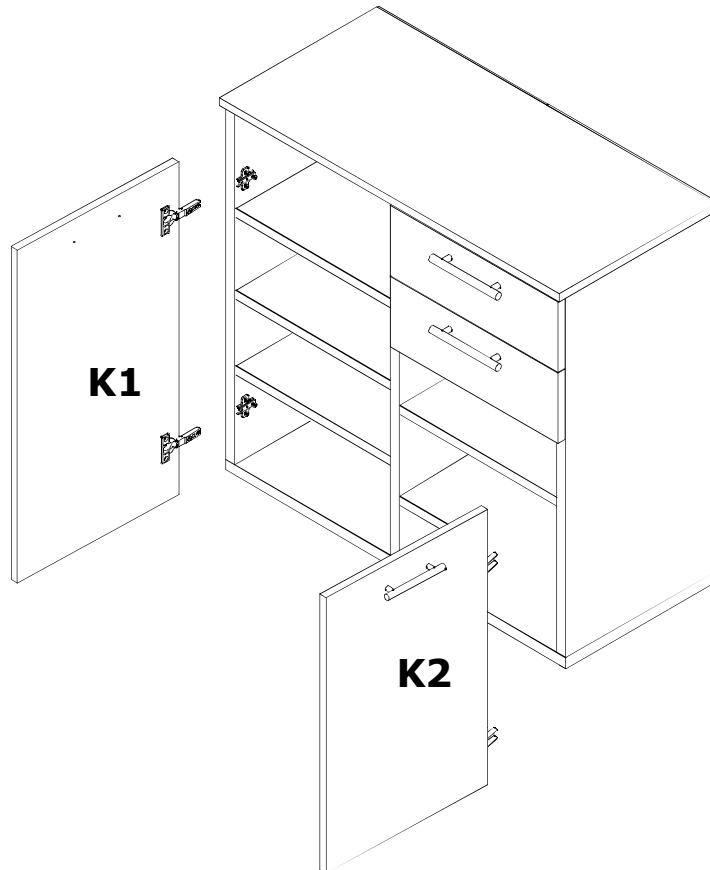
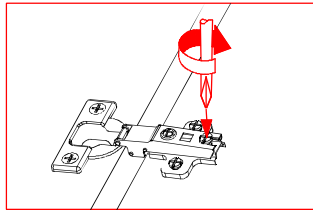
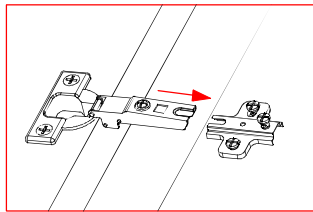
**10****11**

**Türen einstellen (Scharniere justieren)**  
**Adjusting the doors (adjusting the hinges)**  
**Régler les portes (ajuster les charnières)**  
**Sistemare le porte (regolare le cerniere)**  
**Deuren instellen (scharnieren afstellen)**  
**Nastawić drzwi (wyregulować zawiasy)**  
**Vyrovnejte dvířka (seřid'te závěsy)**  
**Nastavenie dverí (nastavenie závesov)**  
**Állítsa be az ajtókat (állítsa be a zsanérokat)**  
**Reglare ușii (ajustare balamale)**  
**Kapıların ayarlanması (menteşelerin seviye ayarı)**  
**Регулировка дверей (регулировка шарнира)**